



SPECIFICATIONS

Customer	
Product Name	Wire Wound SMD Power Inductor
URAI Part Number	1350Series
Customer Part Number	

New Released, Revised]

【This SPEC is tota 6 pages.】

【ROHS Compliant Parts】

Approved By	Checked By	Issued By

Shenzhen Yourui Electronics Co., Ltd.

Address: Second floor, C Building, Huiqing Science and Technology Park, Guanlan Street Dafu Industrial Zone, Longhua District, Shenzhen City, China 518000

【For Customer approval OnYR】

Date: _____

Qualification Status: Full Restricted Rejected

Approved By	Verified By	Re-checked By	Checked By

Comments:



产品名称 DESCRIPTION	一体成型贴片电感 SMD MOLDING POWER INDUCTOR
产品型号 ORDERING CODE	YR1350H-Series

外形尺寸及推荐焊盘 External Dimensions & PCB Pattern :

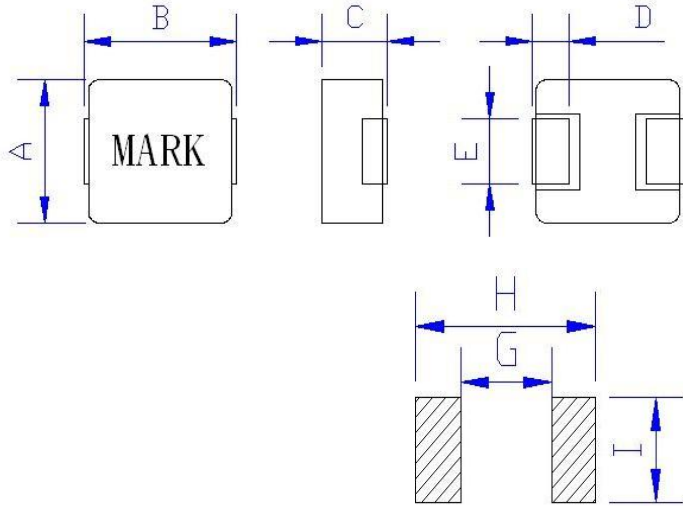

A:	12.8 ± 0.3
B:	14.0 ± 0.5
C:	5.0 Max.
D:	2.5 ± 0.3
E:	3.8 ± 0.3
G:	3.4 Ref.
H:	14.1 Ref.
I:	4.5 Ref.

原理图 Schematic Diagram :

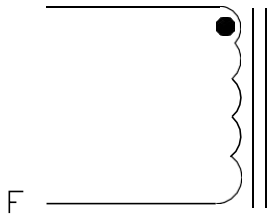

"●" START FOR STAND

物料清单 Material List:

NO	ITEM	MATERIAL	SUPPLIER OF THE MATERIAL
1	CORE	合金粉	YR
2	COPPER	聚酯亚胺漆包线	TOTOKU
3	BLAK	银白色料片	ZS
4	INK	黑色油墨	YMS



产品名称 DESCRIPTION	一体成型贴片电感 SMD MOLDING POWER INDUCTOR
产品型号 ORDERING CODE	YR1350H-Series

电气特性 Electrical Characteristic:

*额定电流：是指基于电感变化率时比标称电感L值低20%和基于温度上升时（因自身发热而温度上升40℃）两者中较小值。

*饱和电流：瞬间加载后电感值 Inductance下降不超过初始电感值 Inductance30%的电流值。

*下列参数为我司常规产品特性，如果不能满足您的需求，请与我们联系。

*测量条件： 1、初始电感量L0：100KHz/1V@25±3℃。

3、工作温度范围：-40℃~85℃。

特性参数 Characteristic Data:

产品料号	L0 (μH) ±20%	直流电阻		额定电流 L rms (A)	饱和电流 L sat (A)
		典型值 Typical	最大值 Max		
YR1350-100M	10.0	15.0	18.0	8.00	14.0
YR1350-150M	15.0	27.0	32.0	7.00	13.0
YR1350-220M	22.0	31.0	38.0	6.00	11.0
YR1350-330M	33.0	54.0	65.0	5.00	9.0
YR1350-470M	47.0	80.0	96.0	4.00	6.0
YR1350-680M	68.0	100	120	3.00	5.0
YR1350-101M	100	155	185	2.50	4.5

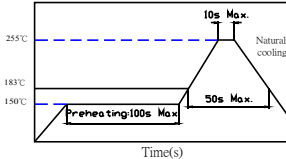
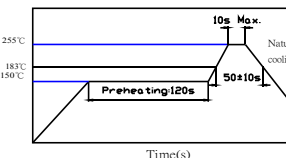

产品名称 DESCRIPTION	一体成型贴片电感 SMD MOLDING POWER INDUCTOR	
产品型号 ORDERING CODE	YR1350H-Series	
测试项目 TEST ITEMS	规格要求 SPECIFICATIONS	测试条件/测试方法 TEST CONDITIONS / TEST METHODS
电气特性测试 ELECTRICAL PERFORMANCE TEST		
电感量 (L)	参照特性参数表 REFER TO STANDARD ELECTRICAL CHARACTERISTIC LIST.	MICROTEST6377
直流电阻 (DCR)		TH2511
额定电流 (IDC)		加载电流后, 电感量下降不超过30%, 或温升不超过40℃ APPLIED THE CURRENT TO COILS THE INDUCTANCE CHANGE SHOULD BE LESS THAN 30% TO INITIAL VALUE AND TEMPERATURE RISE SHOULD NOT BE 40℃ TYPICAL
温升测试 TEMPERATURERISE TEST	温升不超过40℃	加载额定电流, 保持4小时 APPLIED THE ALLOWED DC CURRENT FOR 4 HOURS.
过载测试 OVER LOAD TEST	没有明显的电气损坏 NO EVIDENCE OF ELECTRICAL DAMAGE	加载1.5倍额定电流, 保持5分钟 APPLIED 1.5 TIMES OF RATED ALLOWED DC CURRENT TO INDUCTORS FOR A PERIOD OF 5 MINUTES.
MECHANICAL PERFORMANCE TEST		
耐焊性 SOLDER HEAT RESISTANCE	电感器无外观和电气特性损伤 INDUCTORS SHOULD HAVE NO EVIDENCE OF ELECTRICAL AND MICHANICAL DAMAGE	预热: 150℃ 100s Max. 焊锡温度SOLDER TEMPERATURE: 255±5℃ DIP TIME:10s Max. 
振动测试 VIBRATION TEST	电感量变化不超过10% INDUCTANCE SHOULD NOT HANGE MORE THAN±10%	振幅: 1.5 mm 频率: 10-55-10HZ / 1 MIN 方向: X, Y, Z 时间: 2 HRS/X, Y, Z
冲击测试 SHOCK TEST		待测品从距离地面1米高自由跌落至3厘米后的木板上, 10次INDUCTORS SHOULD BE DROPPED 10 TIMES FROM A HEIGHT OF 1m ONTO 3cm WOODEN BOARD.
可焊性测试 SOLDERABILITY TEST	超过90%的电极被锡覆盖 MORE THAN 90% OF TERMINAL ELECTRODE SHOULD BE COVERED WITH SOLDER.	预热: 150℃ 120s 焊接温度: 255±5℃ 时间:10s Max. 



产品名称 DESCRIPTION	一体成型贴片电感 SMD MOLDING POWER INDUCTOR	
产品型号 ORDERING CODE	YR1350H-Series	
TEST ITEMS	SPECIFICATIONS	TEST CONDITIONS / TEST METHODS
环境测试 CLIMATIC TEST		
温度特性 TEMPERATURE CHARACTERISTIC	无外观破损 APPEARANCE:NO DAMAGE 电感量变化不超过10% INDUCTANCE:WITHIN±10% OF INITIAL VALUE.	-45℃ ~ +85℃
湿度测试 HUMIDITY TEST		60℃±2℃ / 96±2 小时 R.H:90-95%RH
低温储存 LOW TEMPERATURE STORAGE		-45℃±2℃ / 24小时 室温静置1小时后测试 Test at room temperature for 1 hour
冷热冲击测试 THERMAL SHOCK TEST		-45±2℃30分钟, +85±2℃ 30分钟 100次循环 静置2小时后测试 Test at room temperature for 1 hour
高温储存 HIGH TEMPERATURE STORAGE		85℃±2℃ / 24小时 室温静置1小时后测试 Test at room temperature for 1 hour

产品名称 DESCRIPTION	一体成型贴片电感 SMD MOLDING POWER INDUCTOR
产品型号 ORDERING CODE	YR1350H-Series

包装方式PACKAGE TYPE :

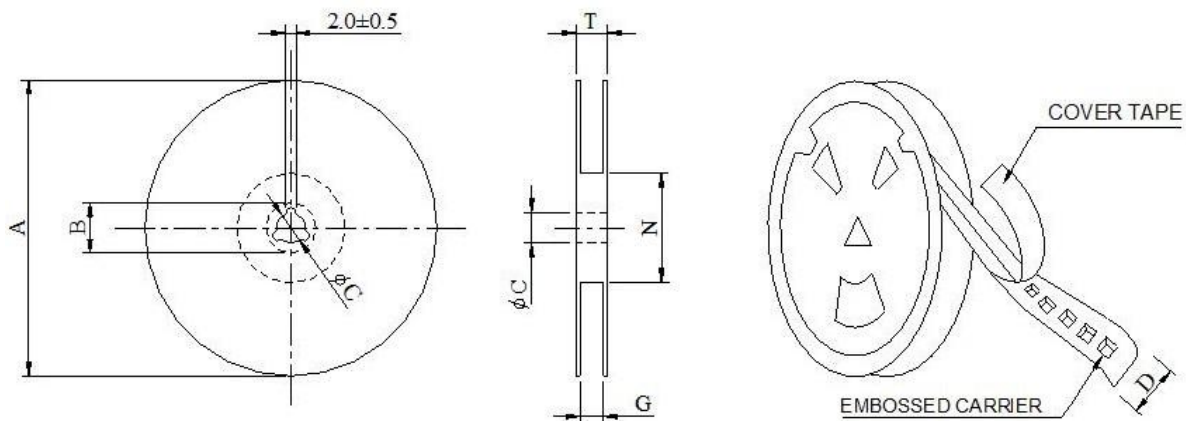

*CARRIER TAPE WIDTH : D

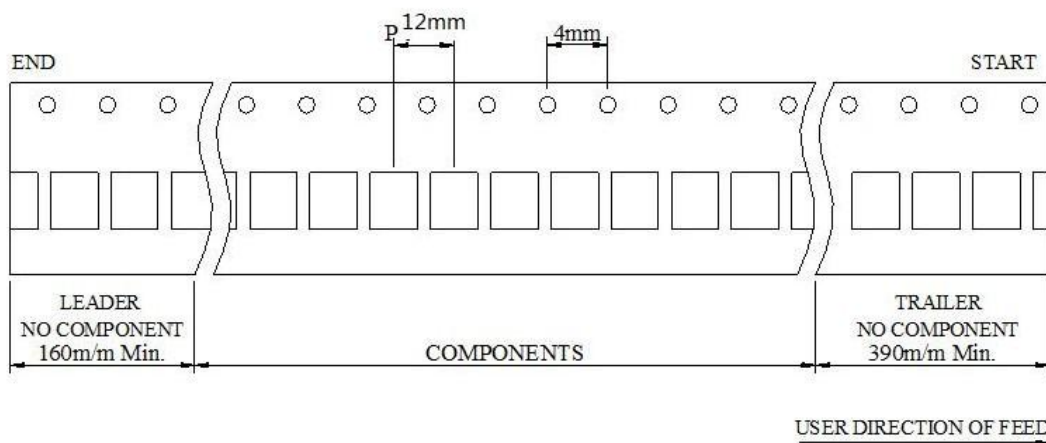

STYLE	DIMENSIONS (m/m)							
	Q'TY (PCS)	A	B±0.8	C±0.5	D	G+0	N-0	T
13	5,00	330	21	13	16	16	100	27